

**MANUAL DE MONTAGEM  
ASSEMBLY INSTRUCTIONS  
INSTRUCCIONES DE MONTAJE**

**COD BR: BMU 52**



# Sumário Summary Resumen

Introdução Introduction Introducción	.....	3
Antes de começar Before starting Antes de comenzar	.....	4
Evite acidentes Avoid accidents Evitar accidentes	.....	4
Dimensões e ferramentas Dimensions and tools Dimensiones y herramientas	.....	5
Identificação das peças Identifying parts Identificación de las piezas	.....	6
Acessórios incluídos na caixa Hardware included in box Accesorios incluidos en la caja	.....	7
Montagem do móvel Furniture assembly Montaje del mueble	.....	8

## Introdução Introduction Introducción

Leia atentamente este manual e siga os passos indicados para que o produto não perca a garantia e também para uma perfeita montagem.

Read this manual and follow the steps in order to keep the guarantee and also for the perfect fit.

Lea este manual y siga los pasos para que el producto no pierda la garantía y también para el ajuste perfecto.

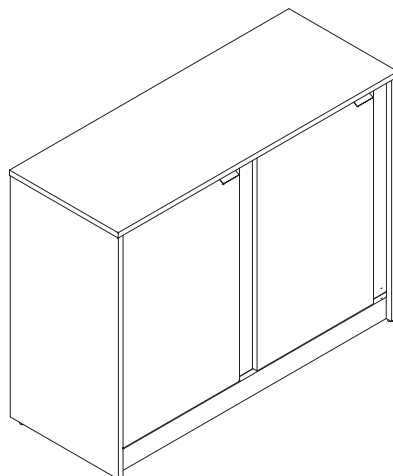

## Antes de começar Before starting Antes de comenzar

Antes de começar a montagem prepare o ambiente, deixando-o completamente limpo e com bom espaço para iniciar o trabalho.

Prepare the room before starting the assembly, leaving it completely clean and the area in good condition to start the work.

Antes de comenzar el montaje preparar el ambiente, dejándolo completamente limpio y con bueno espacio para comenzar el trabajo.

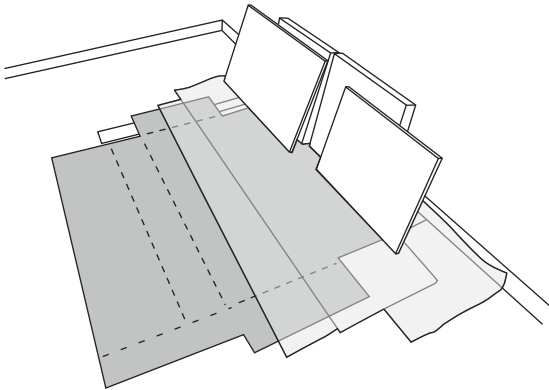

Utilize o papelão da própria embalagem para separar e apoiar as peças retiradas das caixas.

Use the cardboard of the packaging to separate and support the parts removed from the boxes.

Utilice el cartón de la embalaje para separar y apoyar las piezas desmontadas de las cajas.

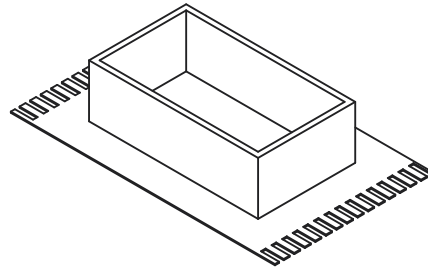

Forre a área de montagem com um cobertor ou tapete. Assim, você evita avarias nas peças durante o processo de montagem.

Cover the assembly area with a blanket or carpet to avoid damaging the parts during the assembly process.

Cubrir la zona de ensamble con una manta o alfombra. De este modo, se evitan daños en las piezas durante el proceso de montaje.



---

## Evite acidentes Avoid accidents Prevenir accidentes

Solicitamos observar atentamente as orientações de montagem como: fixação do produto na parede, colocação de cola em locais específicos necessários, o peso suportado pelo produto, etc...

You are requested to carefully observe the assembly instructions regarding: fixing of products to the wall, adding glue where indicated, product weight limit, etc.

Pedimos que lea atentamente las instrucciones, principalmente las informaciones de fijación del producto en la pared, colocación de pegamento en local específico y necesario, el peso soportado por el producto etc...

Não escale ou se apoie no móvel.

Do not climb or lean on the furniture.

No se suba ni se apoye en el mueble.

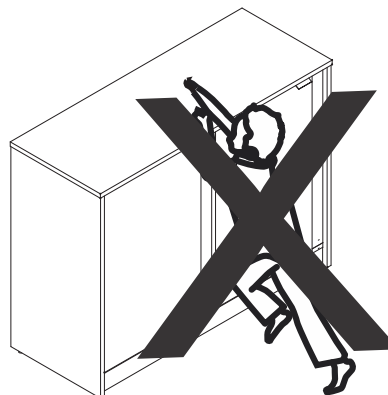

Dimensões e ferramentas  
 Dimensions and tools  
 Dimensiones y herramientas

Dimensões:  
 L: 900 A: 695 P: 350 mm  
 Dimensions:  
 W: 35.43 H: 27.36 D: 13.77 inches  
 Dimensiones:  
 L: 900 A: 695 P: 350 mm

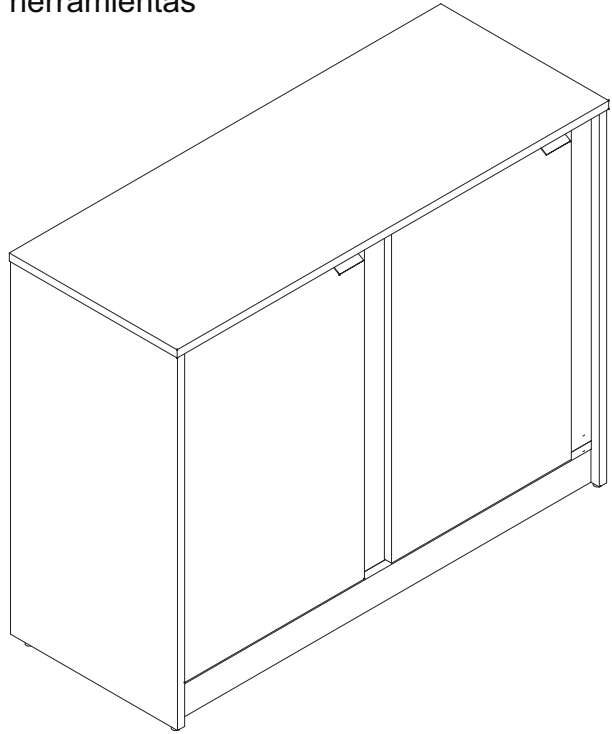

Limpeza  
 Cleaning  
 Limpieza

Pano levemente umedecido com água, seguido de pano seco, não utilizar produtos químico ou abrasivos.  
 You can clean the product with slightly dampened cloth followed by a dry cloth. Do not use chemicals or abrasives.  
 Solamente utilizar un paño húmedo y después un paño seco, no utilice productos químicos o abrasivos.

Todas as peças do móvel foram marcadas com um número. Antes de começar a montagem, identifique as peças numeradas em relação às instruções de montagem. Uma vez concluída a montagem, os números podem ser facilmente removidos com um pano ligeiramente embebido em álcool. Use álcool apenas para remover números das peças.

All the furniture parts have been marked with a number. Before you start assembling, please identify the numbered parts in relation to the assembly instructions. Once assembly is completed, the numbers can be easily removed with a cloth slightly damped in alcohol. Use alcohol only to remove part numbers.

Todos las piezas del mueble fueron marcadas con un número. Antes de empezar el montaje, identifique las piezas numeradas en relación con las instrucciones de montaje. Una vez que se completa el armado, los números se pueden quitar fácilmente con un paño ligeramente empapado en alcohol. Use alcohol solo para eliminar números de las piezas.

**UTILIZE ALCOOL APENAS PARA REMOVER O NUMERO DAS PEÇAS**  
**USE ALCOHOL ONLY TO REMOVE PART NUMBERS**  
**UTILICE ALCOHOL SOLAMENTE PARA ELIMINAR EL NUMERO DE LAS PIEZAS**

Para facilitar a montagem, utilize uma parafusadeira elétrica.  
 To speed assembly, use an electronic screwdriver.  
 Para facilitar el armado, utilice un destornillador eléctrico.

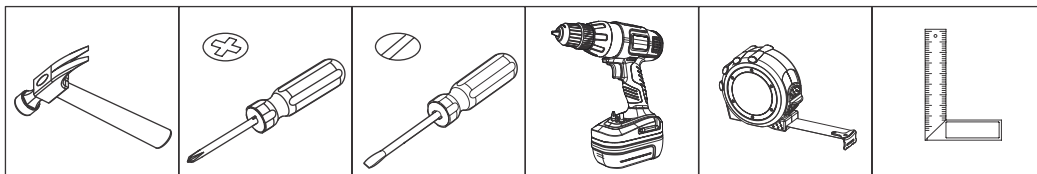

# COD BR: BMU 52

PEÇA	DESCRIÇÃO	QUANT.	PART	DESCRIPTION	QTY	PIEZA	DESCRIPCIÓN	CANTIDAD
001	BASE	1	001	BASE	1	001	BASE	1
002	TAMPO	1	002	TOP	1	002	TAPA	1
003	LATERAL ESQUERDA	1	003	LEFT SIDE	1	003	LATERAL IZQUIERDA	1
004	LATERAL DIREITA	1	004	RIGHT SIDE	1	004	LATERAL DERECHA	1
005	DIVISÓRIA	1	005	PARTITION	1	005	PARTICIÓN	1
006	PRATELEIRA ESQUERDA	1	006	LEFT SHELF	1	006	REPISA IZQUIERDA	1
007	PRATELEIRA DIREITA	1	007	RIGHT SHELF	1	007	REPISA DERECHA	1
008	VISTA	2	008	DETAIL	2	008	VISTA	2
009	RODAPÉ	1	009	BASEBOARD	1	009	RODAPIE	1
010	COSTA	2	010	BACK	2	010	REVÉS	2
011	PORTA	2	011	DOOR	2	011	PUERTA	2

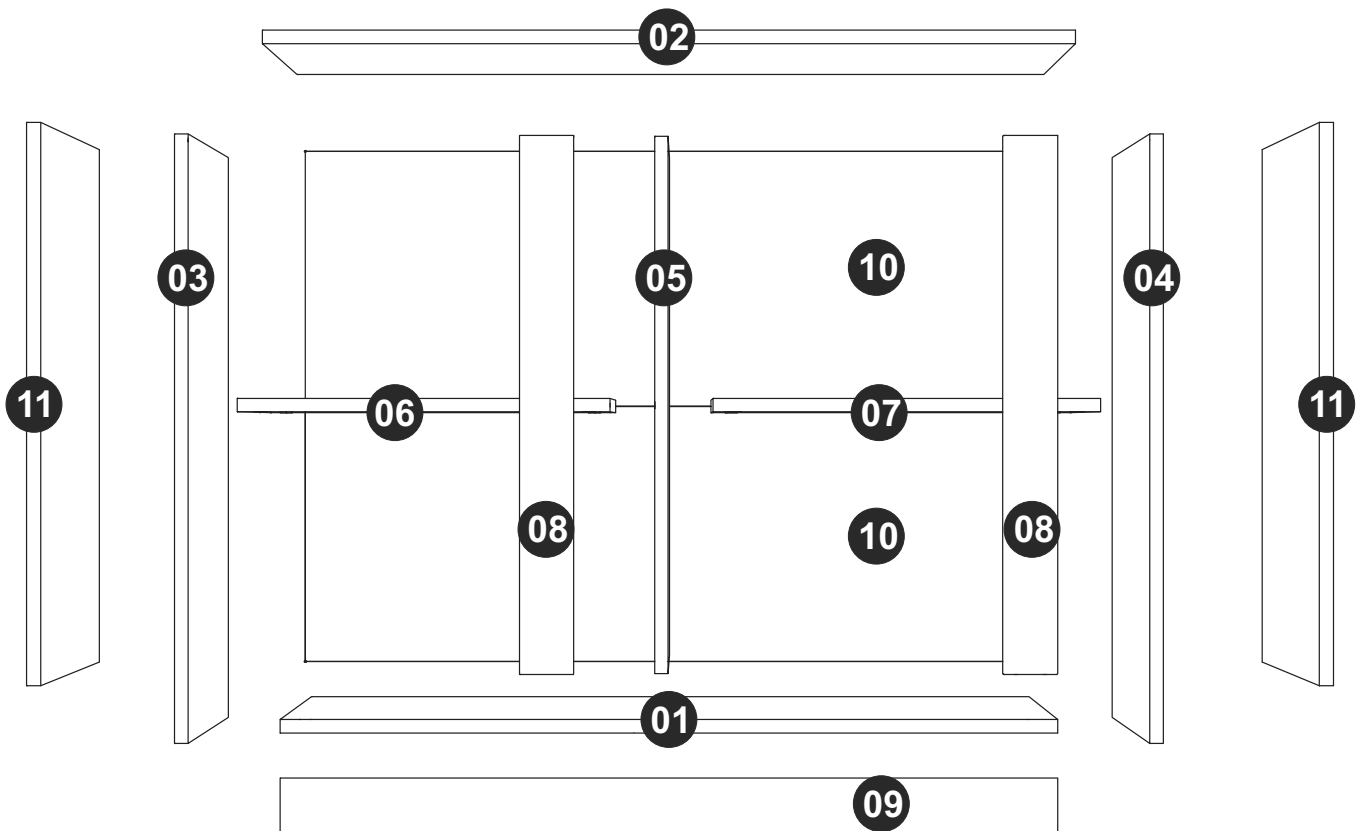



EF 000094 X 14



EF 000067 X 02



EF 000033 x 24  
8x30



EF 000731 x 02  
8x55

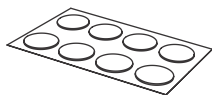

TAPA FUROS x 20  
STICKER x 20  
TAPAS PLÁSTICAS x 20



EF 000107 x 02  
3,5X16 CC



EF 000106 X 24  
3,5X14 CC



EF 000216 X 18



PÉS REDONDOS x 04  
ROUND FEET x 04  
PIES REDONDOS x 04

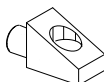

EF 000714 X 02

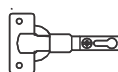

EF 000044 X 04



EF 000024 X 04



SUPOORTE ANGULAR X 02  
ANGULAR SUPPORT X 02  
SOPORTE ANGULAR X 02



GIZ x 01  
CHALK x 01  
TIZA x 01



EF 000168 X 60  
10X10 C/C

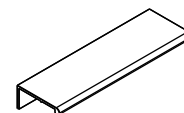

PUXADOR x 02  
HANDLE x 02  
MANIJA x 02



EF 000132 x 02  
4X50 CC

Utilize para medir as ferragens.

Utilice para medir el herraje.

Use for measuring the hardware.

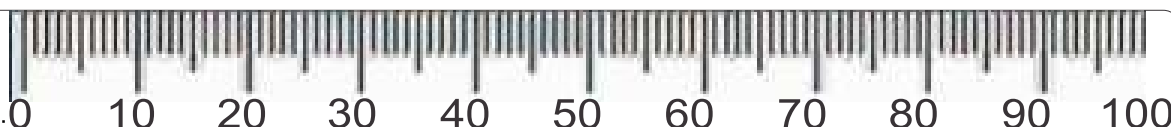

**Garantia (exclusivo para o Brasil/exclusivo de Brasil/exclusive to Brazil):**

A garantia dos produtos fabricados pela BRV Móveis, abrange eventuais defeitos-vícios de fabricação, no prazo estabelecido pelo código de Defesa do Consumidor, em seu artigo 26.II. o qual prevê a garantia de 90 (noventa) dias.

**A** = 11KG - 24.25 LB

**B** = 4KG - 8.81 LB

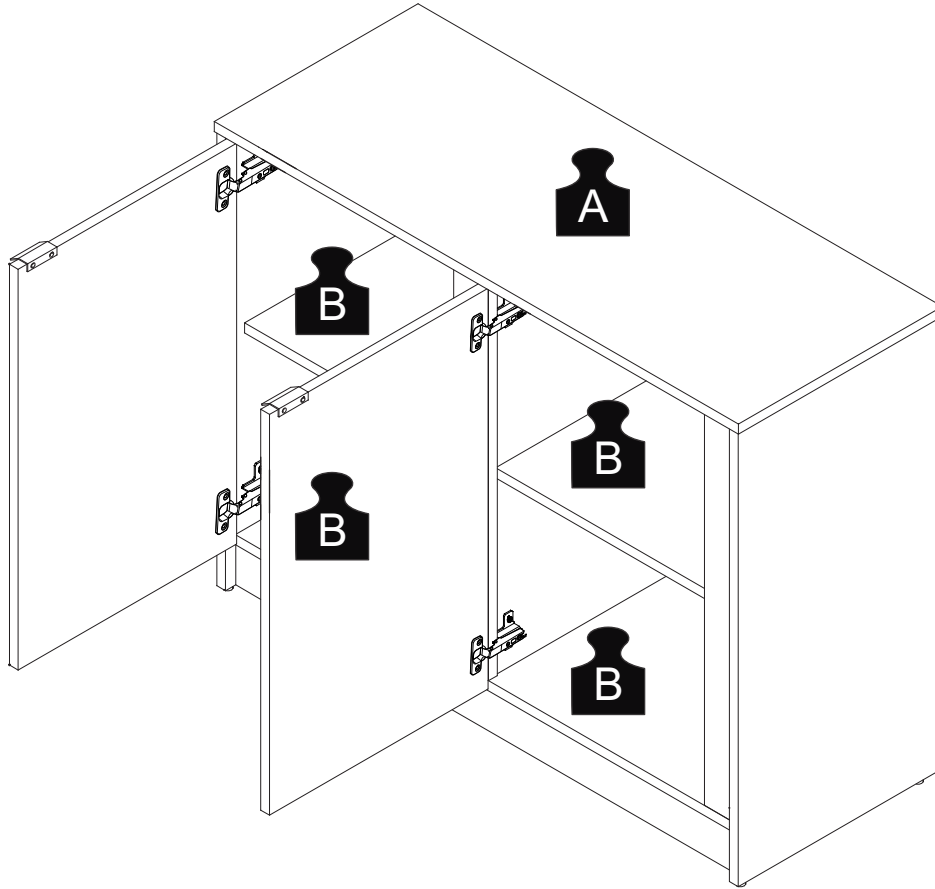

### PASSO 1 / STEP 1 / PASO 1

Insira a ferragem EF 000094 nas peças 02, 03 e 04.  
Insira a ferragem EF 000714 nas peças 03 e 04.  
Insert hardware EF 000094 into pieces 02, 03 and 04.  
Insert hardware EF 000714 into pieces 03 and 04.  
Añade el herraje EF 000094 en las piezas 02, 03 y 04.  
Añade el herraje EF 000714 en las piezas 03 y 04.

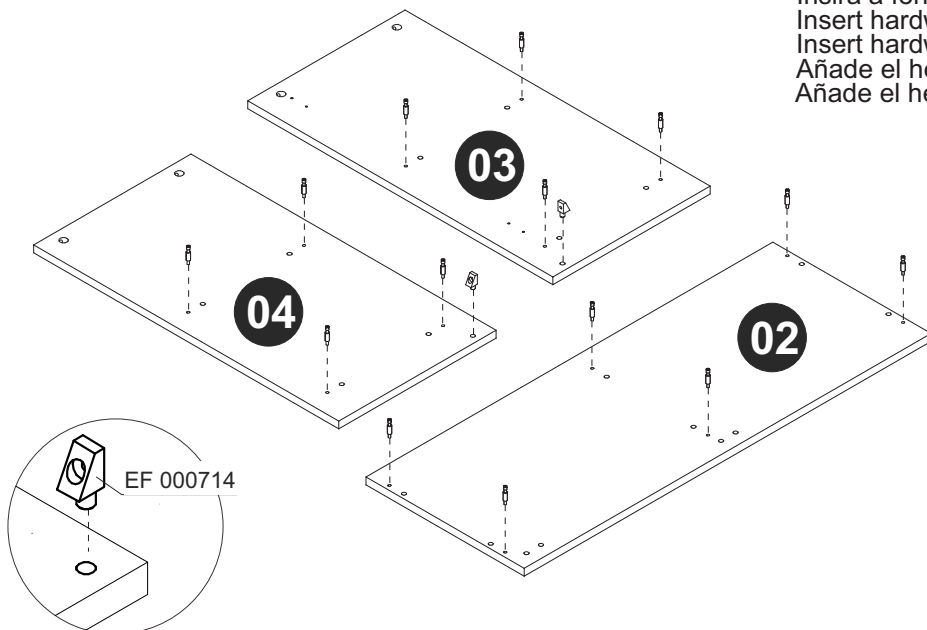



## PASSO 2 / STEP 2 / PASO 2

Insira a ferragem EF 000033 nas peças 03, 04 e 05.  
Fixe a ferragem EF 000025 nas peças 03 e 05 utilizando a ferragem EF 000106.  
Insert hardware EF 000033 into pieces 03, 04 and 05.  
Attach hardware EF 000025 into pieces 03 and 05 using hardware EF 000106.  
Añade el herraje EF 000033 en las piezas 03, 04 y 05.  
Fije el herraje EF 000025 en las piezas 03 y 05 utilizando el herraje EF 000106.

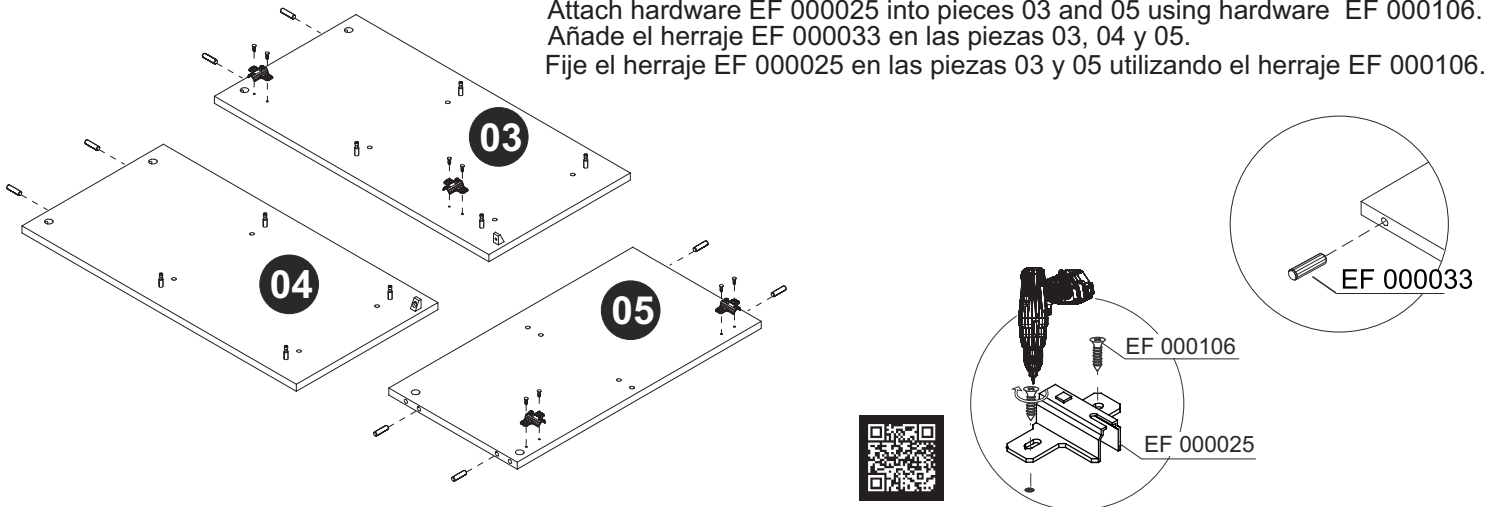

## PASSO 3 / STEP 3 / PASO 3

Insira a ferragem EF 000033 nas peças 01, 06, 07 e 08.  
Insert hardware EF 000033 into pieces 01, 06, 07 and 08.  
Añade el herraje EF 000033 en las piezas 01, 06, 07 y 08.

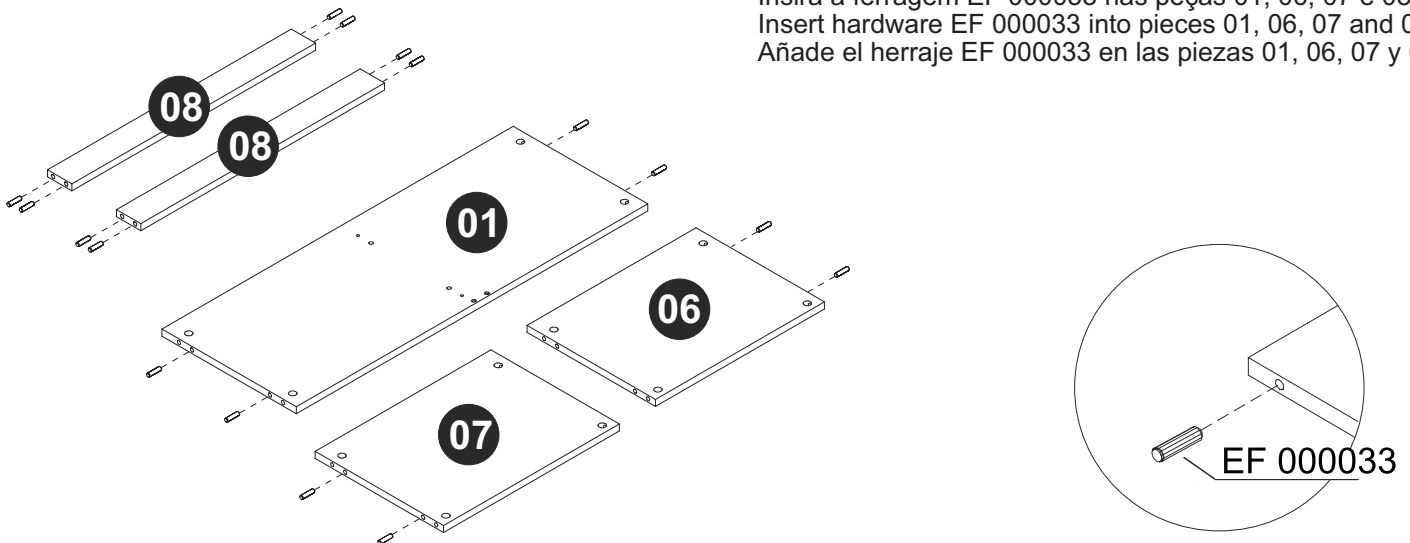

## PASSO 4 / STEP 4/ PASO 4

Fixe o suporte angular na peça 09 utilizando a ferragem EF 000106.  
Attach the angular support into piece 09 using hardware EF 000106.  
Fije el soporte angular en la pieza 09 utilizando el herraje EF 000106.

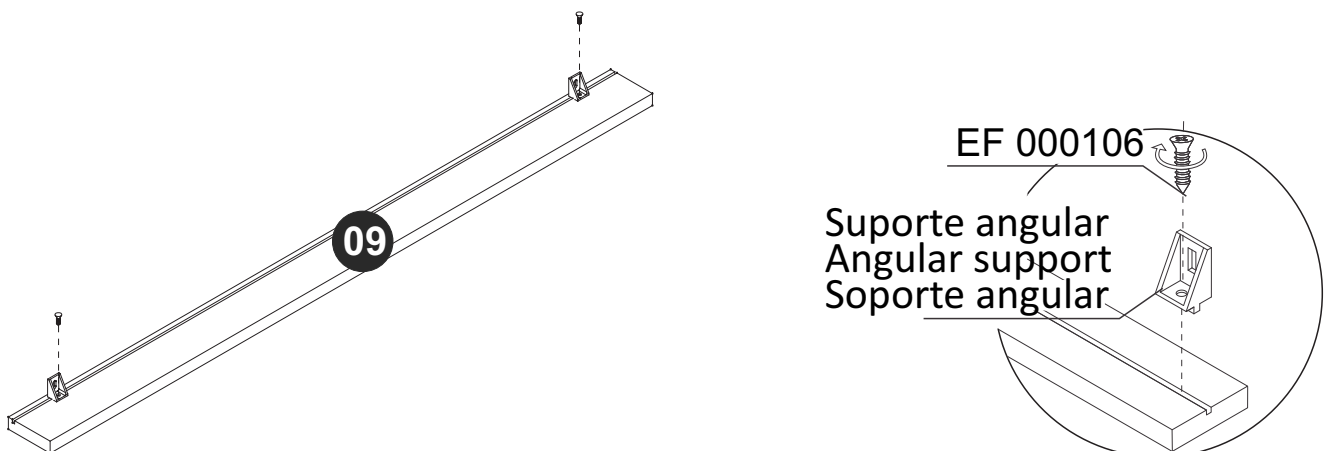

### PASSO 5 / STEP 5 / PASO 5

Fixe a ferragem EF 000043 e o puxador usando a ferragem EF 000106.  
Fix hardware EF 000043 and the handle using hardware EF 000106.  
Fije el herraje EF 000043 y la manija utilizando el herraje EF 000106.

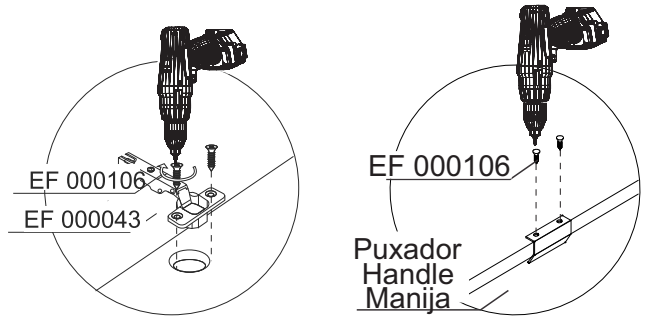
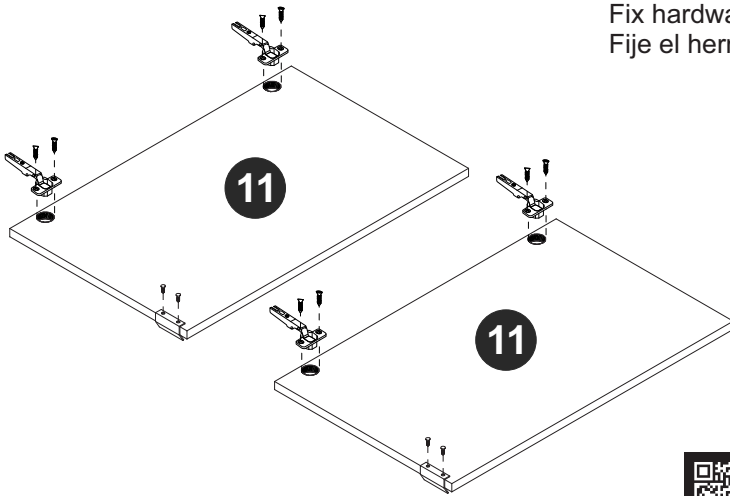

### PASSO 6 / STEP 6 / PASO 6

Insira as ferragens EF 000067 e EF 000731 na peça 05, conecte as peças 06 e 07, insira a ferragem EF 000216 e gire para apertar.  
Insert hardware EF 000067 and EF 000731 into piece 05, connect pieces 06 and 07, insert hardware EF 000216 and turn to tighten.  
Añade el herraje EF 000067 y EF 000731 a la pieza 05, junte las piezas 06 y 07, añade el herraje EF 000216 y gire para apretar.

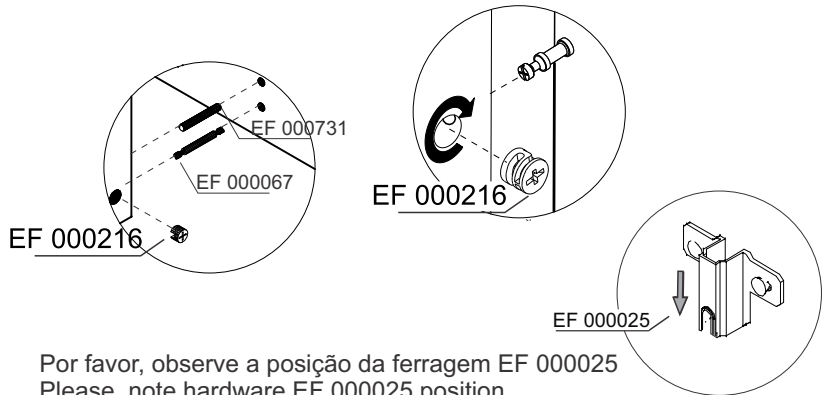
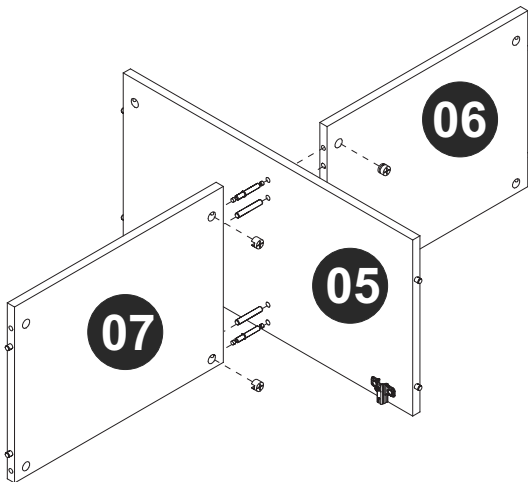

Por favor, observe a posição da ferragem EF 000025  
Please, note hardware EF 000025 position.  
Por favor, observe la posición del herraje EF000025.

### PASSO 7 / STEP 7 / PASO 7

Encaixe as peças 08 na peça 01.  
Conecte a peça 01 à parte montada no passo anterior utilizando a ferragem EF 000132.  
Fix pieces 08 into piece 01.  
Connect piece 01 to the part assembled into the previous step, using hardware EF 000132.  
Fije las piezas 08 en la pieza 01.  
Junte la pieza 01 a la parte armada en el paso anterior, utilizando el herraje EF 000132.

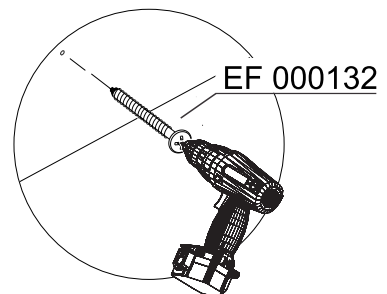
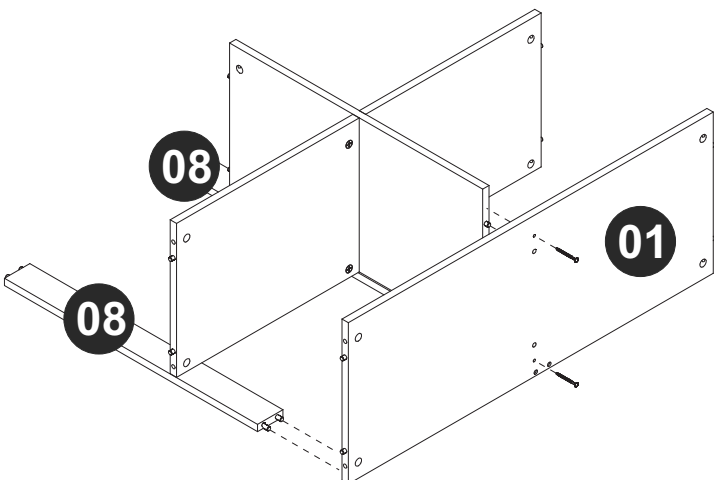

### PASSO 8 / STEP 8 / PASO 8

Conecte a peça 03 à parte montada no passo anterior, insira a ferragem EF 000216 e gire para apertar.  
Connect piece 03 to the part assembled into the previous step, insert hardware EF 000216 and turn to tighten.  
Junte la pieza 03 a la parte armada en el paso anterior, añade el herraje EF 000216 y gire para apretar.

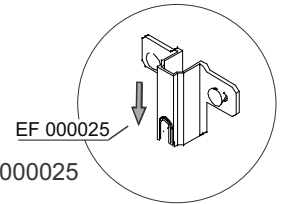
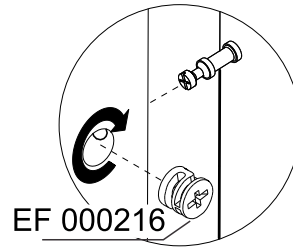
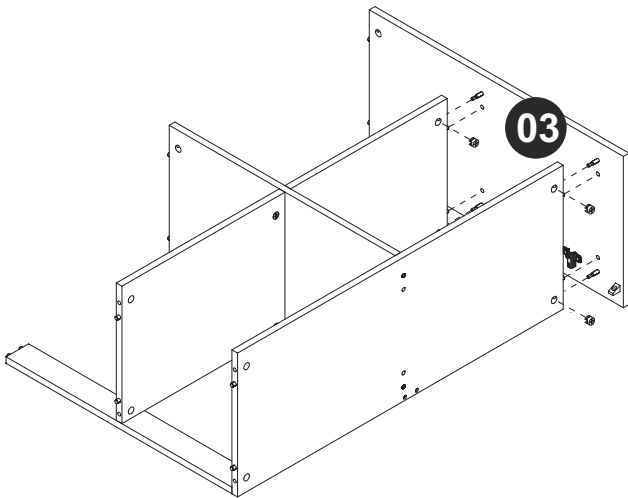

Por favor, observe a posição da ferragem EF 000025  
Please, note hardware EF 000025 position.  
Por favor, observe la posición del herraje EF000025.

### PASSO 9 / STEP 9 / PASO 9

Conecte a peça 04 à parte montada no passo anterior, insira a ferragem EF 000216 e gire para apertar.  
Connect piece 04 to the part assembled into the previous step, insert hardware EF 000216 and turn to tighten.  
Junte la pieza 04 a la parte armada en el paso anterior, añade el herraje EF 000216 y gire para apretar.

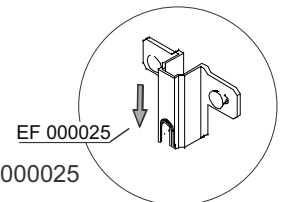
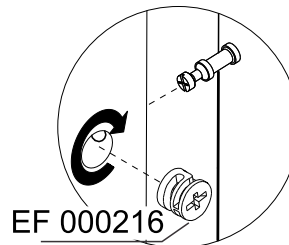
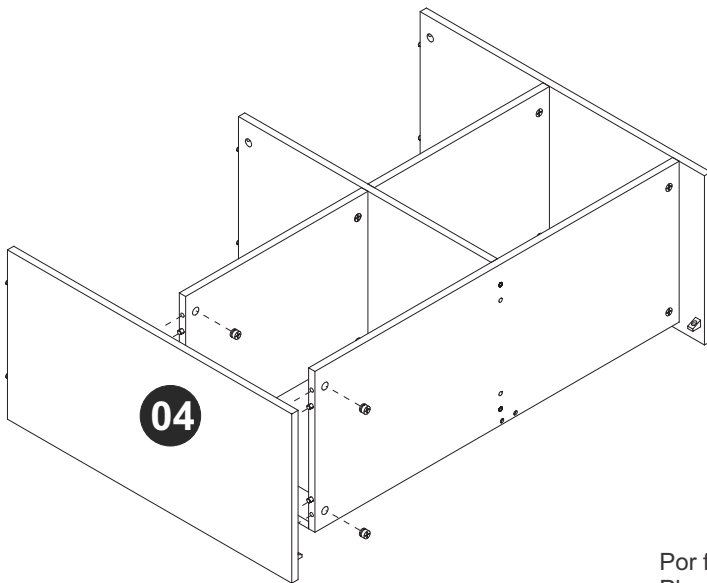

Por favor, observe a posição da ferragem EF 000025  
Please, note hardware EF 000025 position.  
Por favor, observe la posición del herraje EF000025.

### PASSO 10 / STEP 10 / PASO 10

Conecte a peça 02 à parte montada no passo anterior, insira a ferragem EF 000216 e gire para apertar.  
Connect piece 02 to the part assembled into the previous step, insert hardware EF 000216 and turn to tighten.  
Junte la pieza 02 a la parte armada en el paso anterior, añade el herraje EF 000216 y gire para apretar.

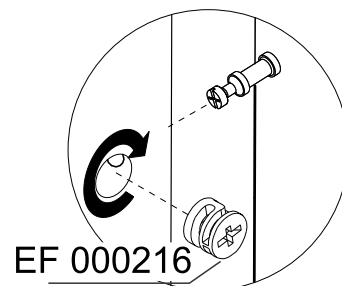
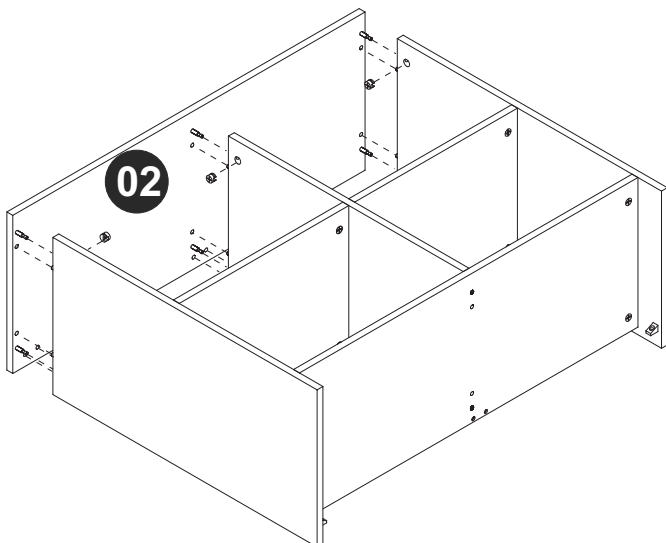

### PASSO 11 / STEP 11 / PASO 11

Fixe a peça 09 utilizando a ferragem EF 000106 e EF 000107.  
Fix the piece 09 using hardware EF 000106 and EF 000107.  
Fije la pieza 09 utilizando el herraje EF 000106 y EF 000107.

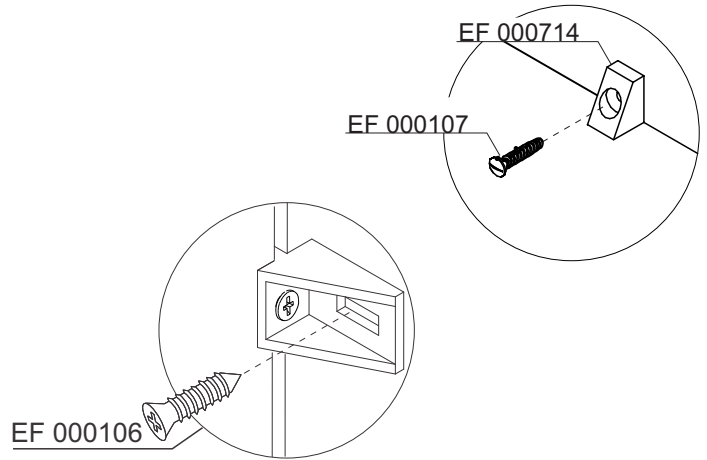
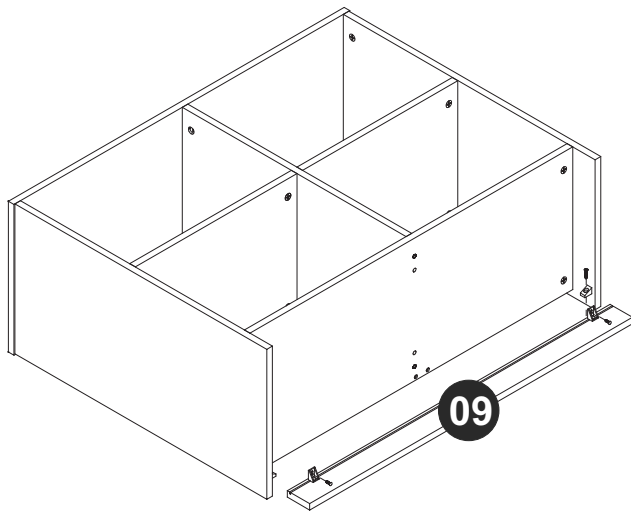

### PASSO 12 / STEP 12 / PASO 12

Fixe as peças 10 e os pés redondos utilizando a ferragem EF 000168.  
Fix the pieces 10 and the round feet using hardware EF 000168.  
Fije las piezas 10 y los pies redondos utilizando el herraje EF 000168.

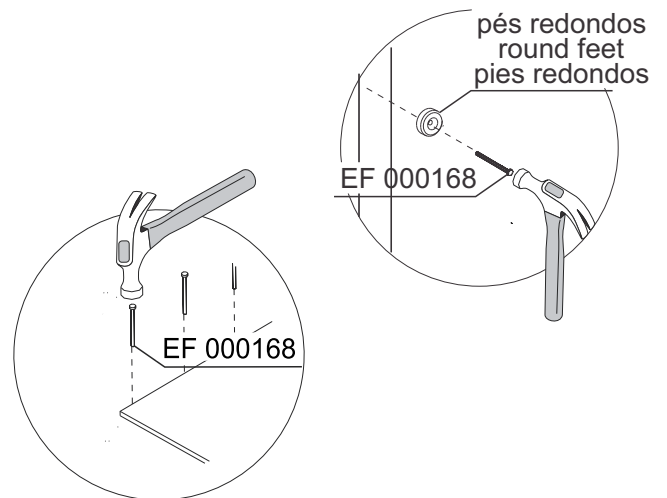
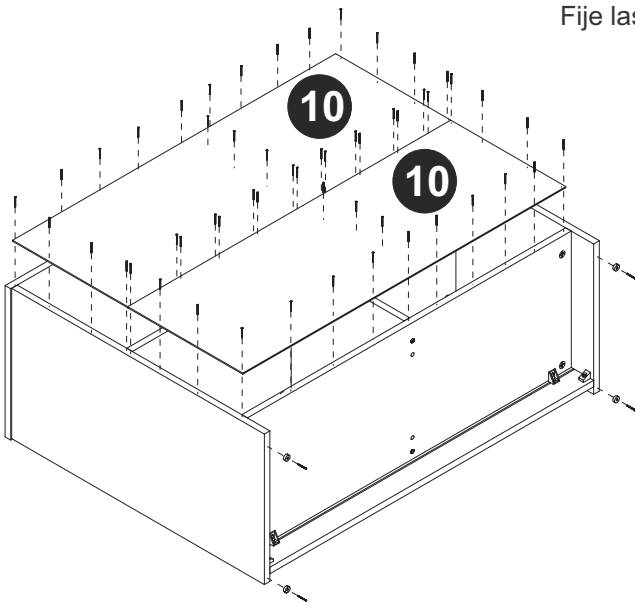

### PASSO 13 / STEP 13 / PASO 13

Fixe as peças 11 ao móvel montado.  
Fix pieces 11 to the assembled furniture.  
Fije las piezas 11 al mueble armado.

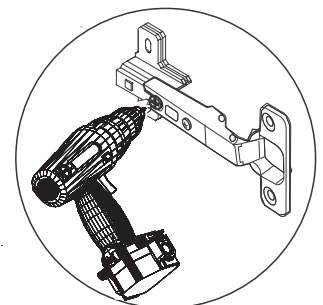
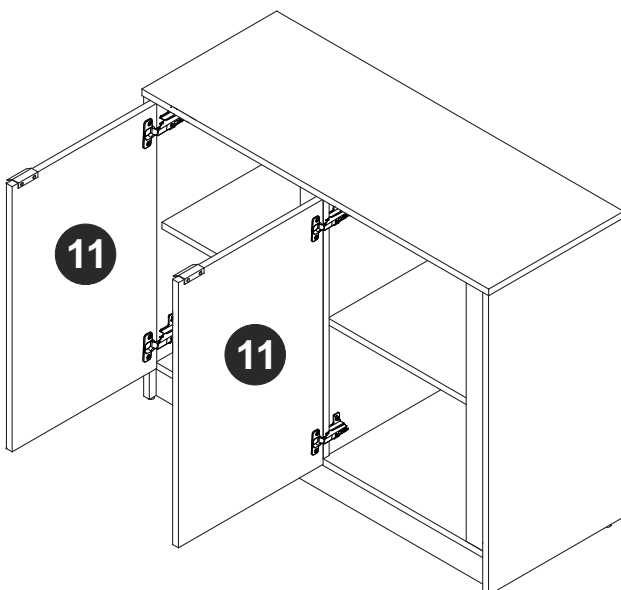

### PASSO 14 / STEP 14 / PASO 14

Utilize o tapa furos para cobrir os parafusos aparentes.  
Use the sticker to cover the apparent screws.  
Utilice los tapa huecos para cubrir los tornillos aparentes.

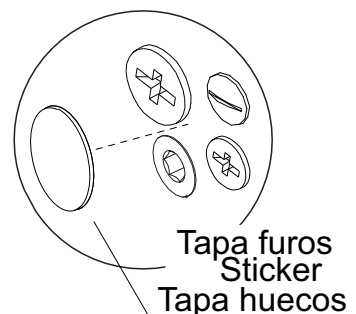
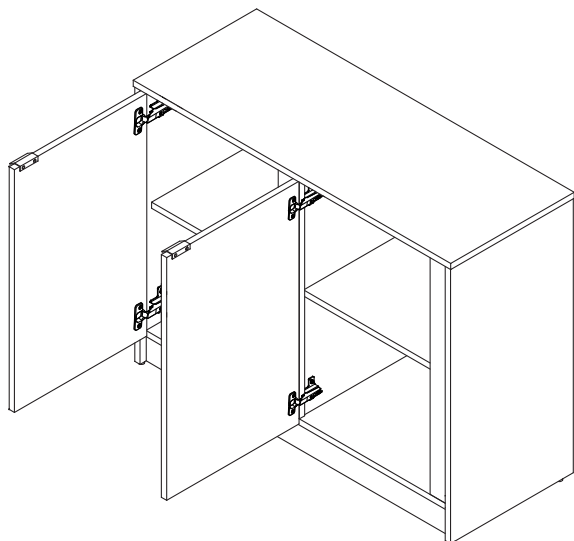

### PASSO 15 / STEP 15 / PASO 15

Utilize o giz para dar o acabamento final ao produto.  
Use the chalk to give the final finish on the product.  
Utilize la tiza para dar el acabado final al producto.

